

Installation Note

Agilent Technologies ESG Vector Signal Generator

**E4423B, E4424B, E4425B, E4426B,
E4434B, E4435B, E4436B, and E4437B**

Semi-Rigid Cable Replacement Kits

Kit Part Numbers:

E4400-60750,

E4400-60751,

and E4400-60752



Agilent Technologies

**Part Number E4400-90660
Printed in USA August 2007**



E4400-90660

Notice

The information contained in this document is subject to change without notice.

Agilent Technologies makes no warranty of any kind with regard to this material, including but not limited to, the implied warranties of merchantability and fitness for a particular purpose. Agilent Technologies shall not be liable for errors contained herein or for incidental or consequential damages in connection with the furnishing, performance, or use of this material.

Agilent Technologies ESG Vector Signal Generator

**E4423B, E4424B, E4425B, E4426B,
E4434B, E4435B, E4436B, and E4437B**

Semi-Rigid Cable Replacement Kits

Kit Part Numbers: E4440-60750, E44000-60751, and E4400-60752

Product Affected:	E4423B, E4424B, E4425B, E4426B, E4434B, E4435B, E4436B, and E4437B
Serial Numbers:	All
Options:	All
To Be Performed By:	(X) Agilent Technologies Service Center () Personnel Qualified by Agilent Technologies () Customer
Estimated Installation Time:	1.0 hours
Estimated Verification Time:	1.0 hours

Introduction

This kit contains the parts and instructions to replace the semi-rigid cables on the E4438C Vector Signal Generator.

Installation includes the following steps:

1. Functionality Check.
2. Remove the outer and inner covers.
3. Remove daughterboard card cage boards.
4. Remove the old semi-rigid cables.
5. Install the new semi-rigid cables.
6. Replace daughterboard card cage boards.
7. Replace inner covers.
8. Verify the functionality of the signal generator.
9. Re-calibrate the signal generator.
10. Re-assemble the signal generator
11. Perform the functionality check of the signal generator.

Installation Kit Parts List

Table 1 Replacement Cable Kit for W42 E4400-60750

Item	Quantity	Description	Part Number
1	2	Retainer Ring	0510-1643
2	2	Retainer Cable	E4400-40002
3	1	Cable AY Jumper	E4423-20025
4	1	Installation Note	E4400-90660

Table 2 Replacement Cable Kit for W43 E4400-60751

Item	Quantity	Description	Part Number
1	2	Retainer Ring	0510-1643
2	2	Retainer Cable	E4400-40002
3	1	Cable out to Synth	E4423-20026
4	1	Installation Note	E4400-90660

Table 3 Replacement Cable Kit for W44 E4400-60752

Item	Quantity	Description	Part Number
1	1	Retainer Ring	0510-1643
2	1	Retainer Cable	E4400-40002
3	1	Cable Coherent Carrier	E4400-20024
4	1	Installation Note	E4400-90660

Tools Required

- TORX T-10 driver
- TORX T-15 driver
- TORX T-20 driver
- Long Nose pliers
- 5/16 open-ended wrench

Safety Considerations

WARNING **Before you disassemble the instrument, turn the power switch off and unplug the signal generator. Failure to unplug the signal generator can result in personal injury.**

CAUTION Electrostatic discharge (ESD) can damage or destroy electronic components. All work on electronic assemblies should be performed at a static-safe workstation.

Checking Signal Generator Functionality

Use the following procedure to confirm that the signal generator powers on and that the internal check does not identify errors. The internal check evaluates the operation of the signal generator and returns an error message if it detects a problem.

NOTE When signal generators are first connected to ac line power, the error message ERROR 514, Reference Oven Cold occurs, which causes both the OVEN COLD annunciator and the ERR annunciator to turn on.

After approximately five minutes, the OVEN COLD annunciator automatically clears, but the ERR annunciator remains on until all errors are cleared from the error queue.

1. Turn on the signal generator and let it warm up for at least thirty minutes.
2. Run the instrument self-test by pressing **Utility > Instrument Info/Help Mode > Self Test > Run Complete Self Test**. Upon completion, a summary of the self-test will be displayed. Use the service guide to troubleshoot any failures detected by the test.

NOTE Some circuits may require up to 50 minutes to warm up before passing the self-test. If self-tests continue to fail after 50 minutes of warm up, troubleshoot the instrument.

3. Check to see if the ERR annunciator is on.
 - If the ERR annunciator is on, review the error messages in the error queue by pressing **Utility > Error Info > View Next Error Message**. The first error message in the error queue appears in the display text area. (Refer to the signal generator error messages document for information about each error message.)
After resolving all problems causing errors, press **Utility > Clear Error Queue(s)**.
 - If the ERR annunciator is off, the signal generator functionality check has passed.

Removing Outer and Inner Covers

Tools Required

- TORX T-10 driver
- TORX T-15 driver
- TORX T-20 driver

Removing the Outer Cover

Refer to [Figure 1](#).

1. Disconnect the power cord.
2. Using a T-20 driver, remove the two strap handles (1) by loosening the screws.
3. Using a T-15 driver, remove the center screws (3) on the four rear-panel feet (2).
4. Remove the four bottom feet (5) and (6) from the cover by pushing and pulling the tab.
5. Slide the outer cover (4) off the frame.

Removing the Inner Top Cover

Refer to [Figure 1](#).

1. Using a T-10 driver, remove the ten screws (10) from the inner-top cover (7).
2. Remove the inner-top cover.

Removing the Instrument Side Cover

Refer to [Figure 1](#).

1. Using a T-10 driver, remove the four screws (8) from the inner-side cover (9).
2. Slide the inner-side cover forward to unlock the sheet metal from the chassis.
3. Remove the inner-side cover.

Figure 1

Outer and Inner Cover Removal

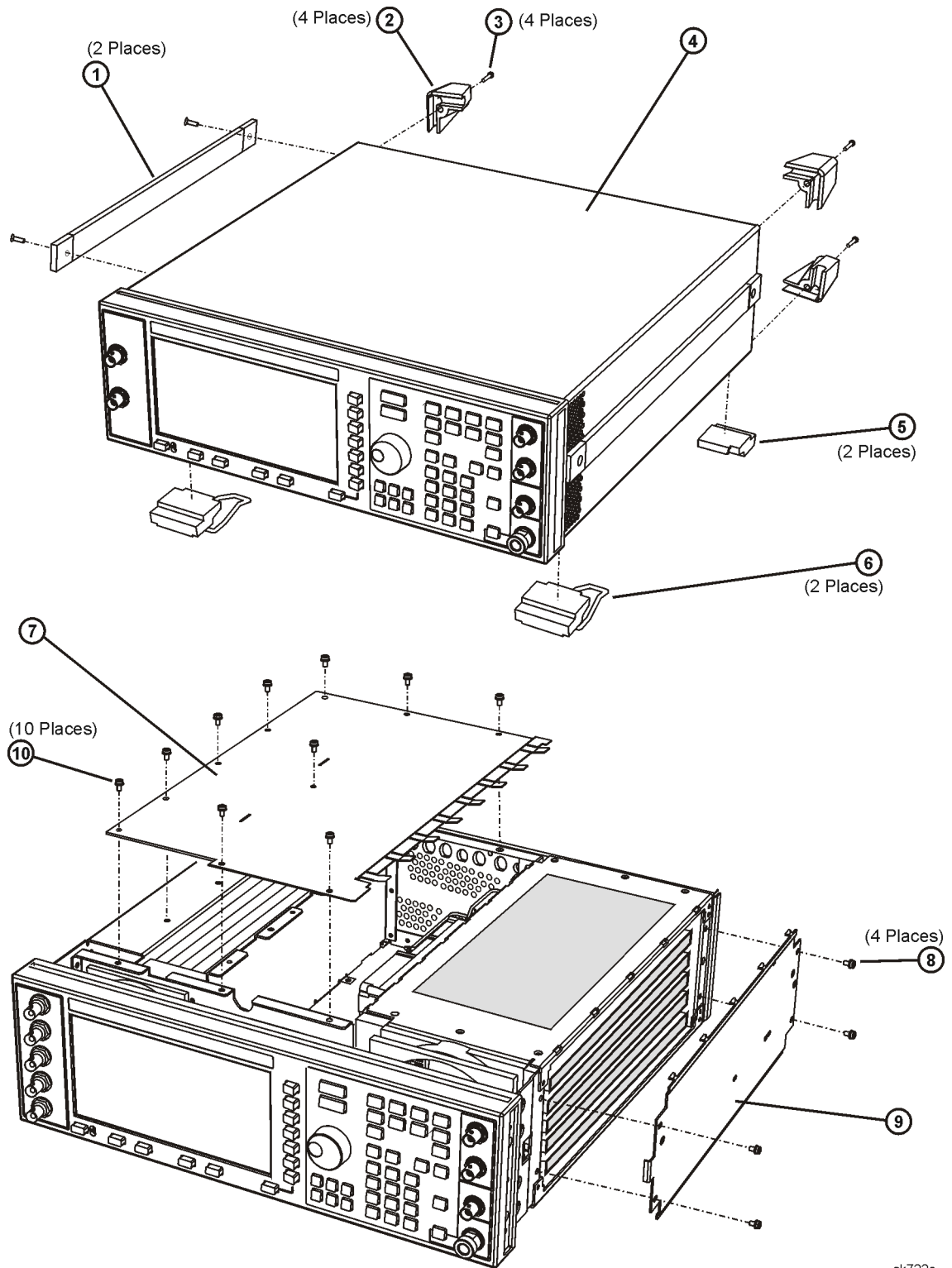

sk722c

Removing A9, A11, A23, and A24 Daughter Card Cage Boards

Refer to [Figure 2](#).

Use this procedure to remove any one of the following assemblies:

- A9 Output Board
 - A11 Reference Board
 - A23 Sampler Board
 - A24 Frac-N Board
1. Remove the right-side cover by removing the four screws that attach it to the instrument chassis.
 2. Simultaneously lift the left and right extractors on the board that you want to remove.
 3. Remove the board from the card cage slot.

Figure 2 **A9, A11, A23, and A24 Daughterboard Card Cage Boards**

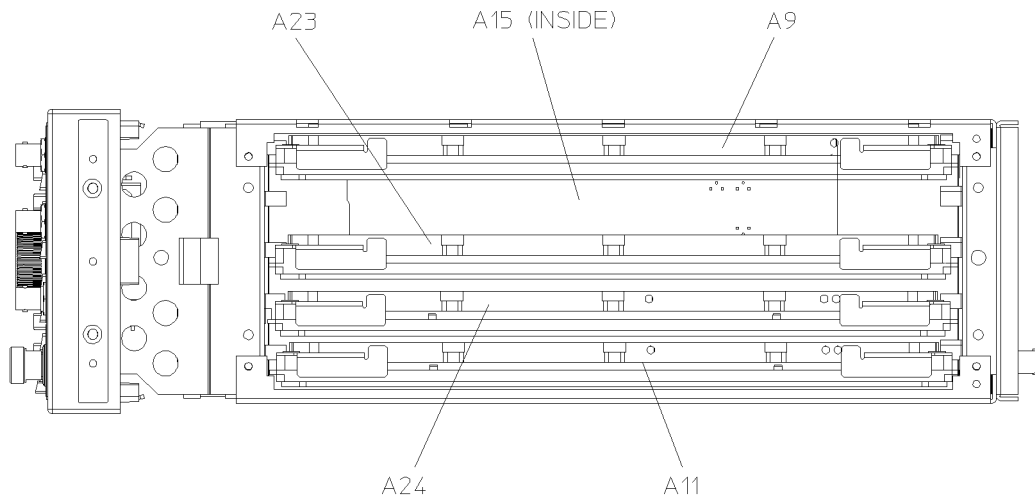

sk7115b

Replacing W42, W43, or W44

Remove Old Semi-Rigid Cables

For ESG-AP and ESG-DP Series Signal Generators, refer to [Figure 3](#).

For ESG-AP and ESG-DP Series Signal Generator with Option UNB, refer to or [Figure 4](#).

1. Refer to [Figure 5](#). Remove the snap ring (1) from the cable retainer (2) of the cable you want to remove. The cable is now disconnected from the instrument chassis (3).
2. Disconnect the other end of the cable (4) and remove the cable.

Figure 3 W42, W43, and W44 Semi-Rigid Cable Locations for ESG-AP and ESG-DP Series Signal Generators

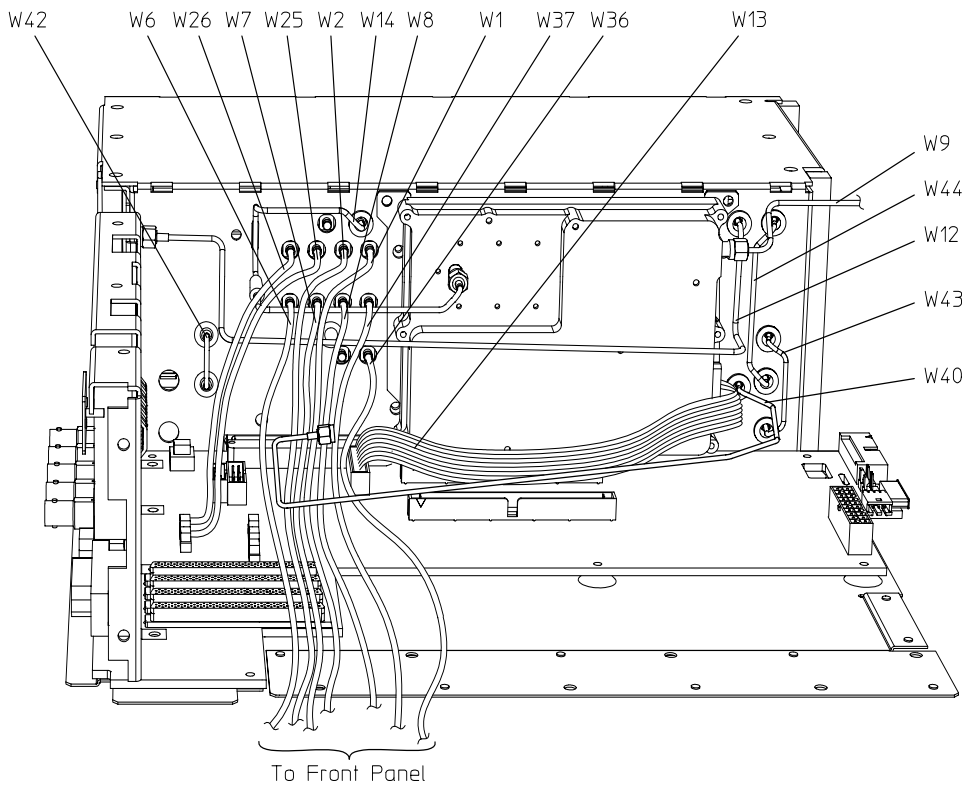

sk7126b

Figure 4 **W42, W43, and W44 Semi-Rigid Cable Locations for ESG-AP and ESG-DP Series Signal Generators with Option UNB**

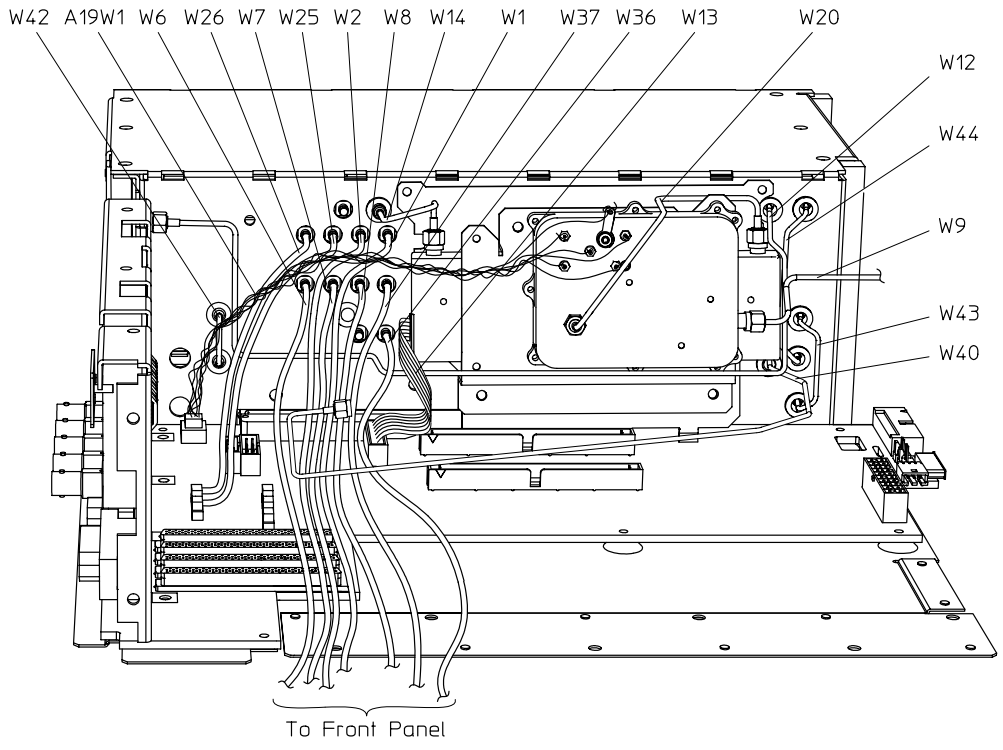

sk7144b

Figure 5

Cable Retainer

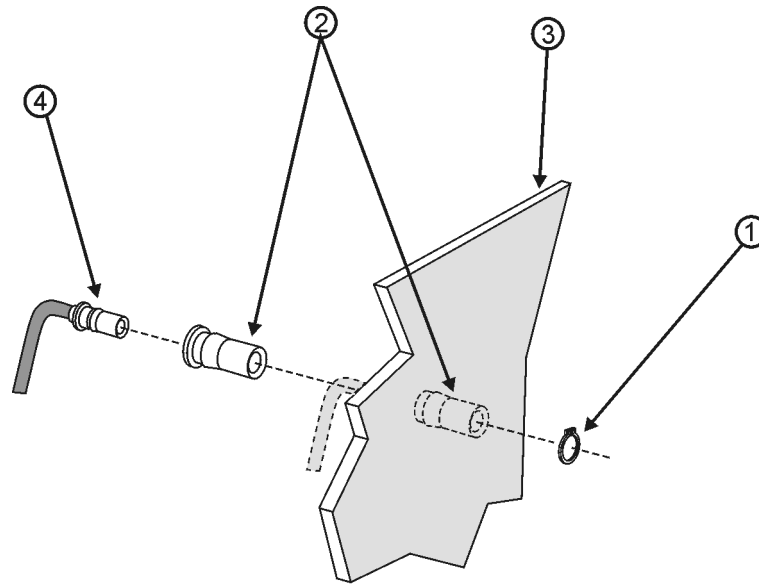

Connect New Semi-Rigid Cables

Refer to [Figure 5](#).

1. When installing a new cable, a new cable retainer (2) must be attached to one end of the cable (4). Verify the cable retainer is correctly attached by listening for a click, as you slide the cable retainer over the end of the cable.
2. Insert the end of the cable that has the cable retainer connected to it, into the opening of the instrument chassis. Secure it with a snap ring (1).
3. Connect the other end of the cable to the appropriate location. Torque to 9 in-lbs.

Replace Daughterboard Card Cage Boards

1. Replace the board(s) into the card cage slot. Refer to [Figure 1](#).
2. Press down on the retention levers until the board connects with the A19 Daughterboard.

Replace the Inside Top and Side Covers

Refer to [Figure 1](#).

1. Reinstall the inside top (7) and side (9) covers by reversing the order of the steps in the [“Removing the Inner Top Cover”](#) and [“Removing the Inner Top Cover”](#) procedures.
2. Torque all T-10 screws to 9 in-lbs.

Verification of Signal Generator Operation Signal Generator

1. Turn the signal generator on. Let the signal generator warm up for five minutes.
2. Press the front panel PRESET button to reset the signal generator.
3. Check for error messages.
 - If error messages occur, refer to [“Checking Signal Generator Functionality”](#) on page 6, to clear the error messages.
 - If no error messages are present, the signal generator should function properly.

Instrument Calibration and Performance Tests

1. Allow it to warm up for 30 minutes.
2. Perform the calibration adjustments as called out in the “Post repair Procedures” chapter of the service guide.
3. Perform the instrument performance tests as called out in the “Post Repair Procedures” chapter of the service guide.

Re-Assembling the Instrument

Refer to [Figure 1](#).

1. Turn the instrument off and unplug it.
2. Reinstall the outer instrument cover by reversing the order of the steps in the [“Removing the Outer Cover”](#) procedure.
3. Torque all T-10 screws to 9 in-lbs.
4. Torque all T-15 and T-20 screws to 21 in-lbs.

Perform the Functionality Check of the Signal Generator

1. Reboot the signal generator, allowing it to warm up for five minutes.
2. Press the front panel PRESET button to reset the signal generator.
3. Check for error messages.
 - If error messages occur, refer to [“Checking Signal Generator Functionality” on page 6](#) to clear the error messages.
 - If no error messages are present, the signal generator should function properly.